

BRISTAN

Hourglass Extension Tap Range

Installation Instructions & User Guide

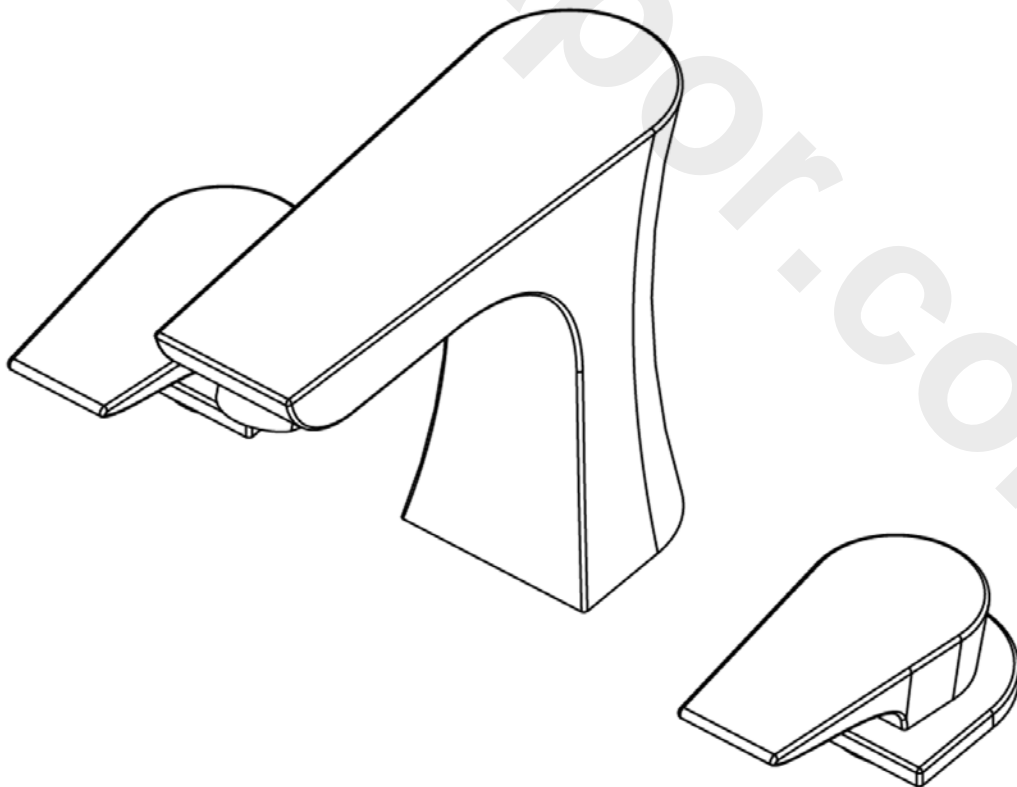

Please keep these instructions for future reference

Important Safety Information

- Please read these instructions thoroughly and retain for future use.
- All products manufactured and supplied by Bristan are safe provided they are installed correctly, used correctly and receive regular maintenance in accordance with these instructions.
- **If you are in any doubt about your ability to install this product safely you must employ the services of an experienced qualified plumber.**
- Remove all packaging and check the components for damage before starting installation.
-  Before starting any installation please consider the following: Prior to drilling into walls, check that there are no hidden electrical wires, cables or water supply pipes. This can be checked with the aid of an electronic detector.
- If power tools are used do not forget to:
 - Wear eye protection
 - Unplug equipment after use
- This product **must** not be modified in any way as this will invalidate the guarantee.
- These fittings need to be installed in accordance with and meet the requirements of the Water Supply (Water Fittings) Regulations 1999 and Scottish Byelaws 2004.

General Specifications

Operating pressure range (bar)	Min	Max
1 Hole Bath Filler	1.0	5.0
3 Hole Basin Mixer	0.2	5.0
3 Hole Bath Filler	0.2	5.0
5 Hole Bath Shower Mixer	0.4	5.0
Maximum static pressure – 10.0 bar		

NOTE:- Nominally equal (balanced) inlet supply pressures are recommended for optimum Performance of mixer taps.

Designed to comply with BS EN 200 for single taps / combination taps for water systems of type 1 and 2 general technical specifications; and to be used within systems designed to BS 6700.

BS 6700 recommends the temperature of stored water should never exceed 65°C. A stored water temperature of 60°C is considered sufficient to meet all nominal requirements and will minimise the build up of lime scale in hard water areas.

Dimensions

1 Hole Bath Filler

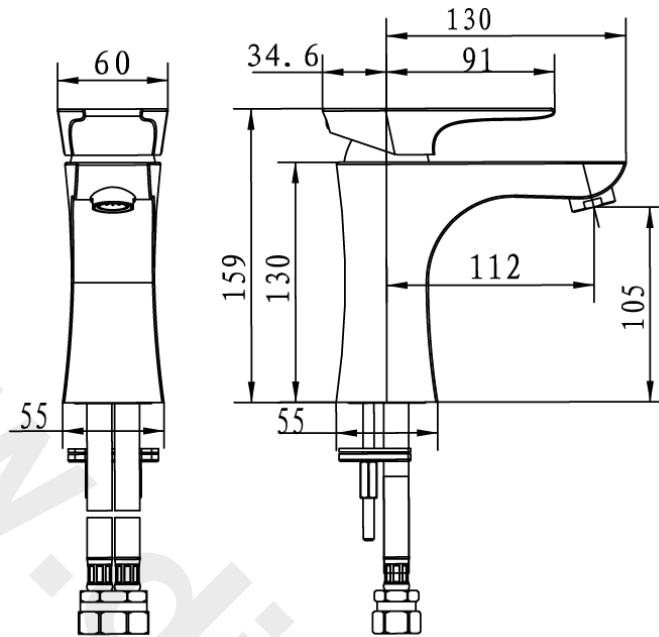

3 Hole Basin Mixer

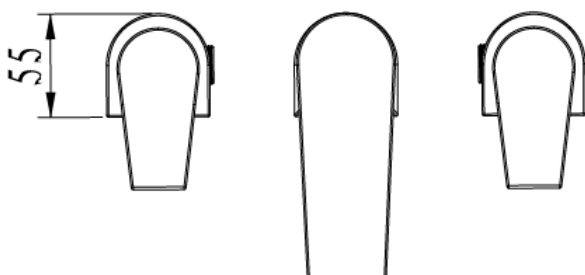
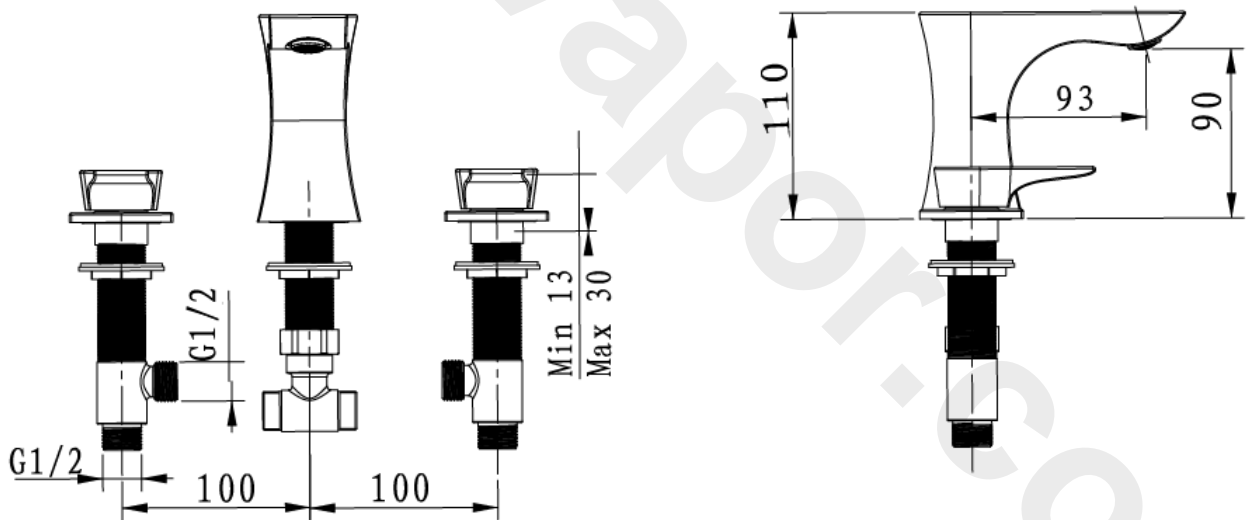

Dimensions Cont.

3 Hole Bath Filler

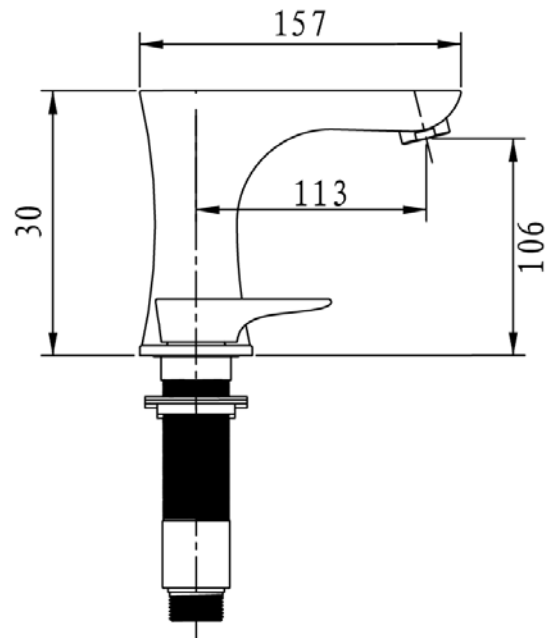
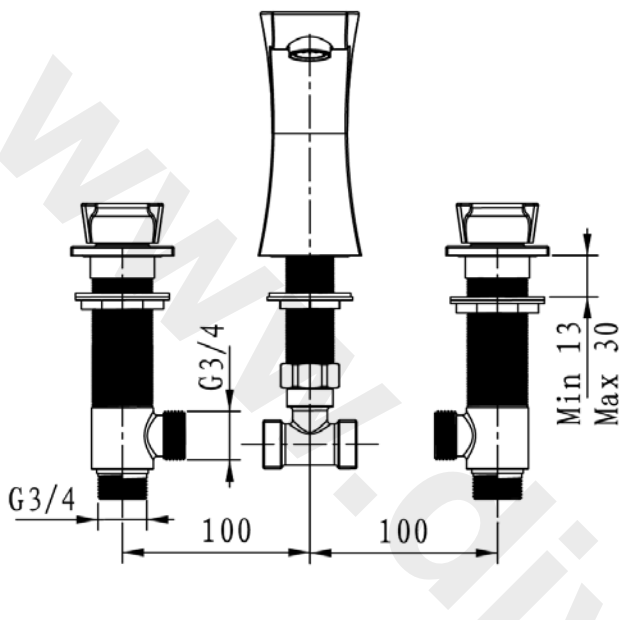

5 Hole Bath Shower Mixer

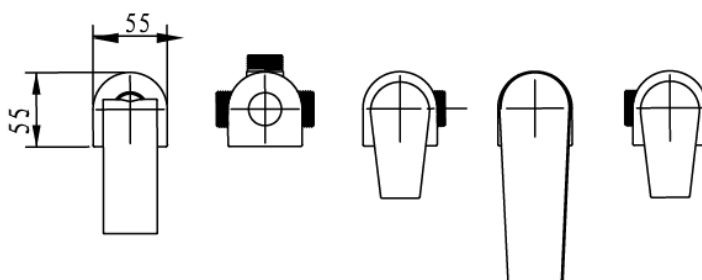
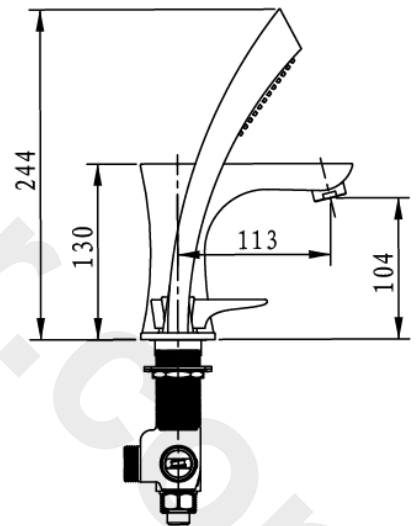
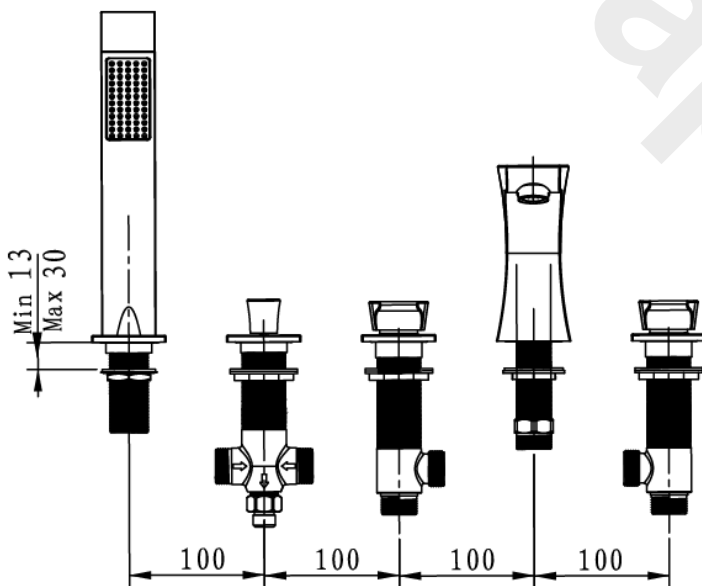

Installation

1 Hole Bath Filler

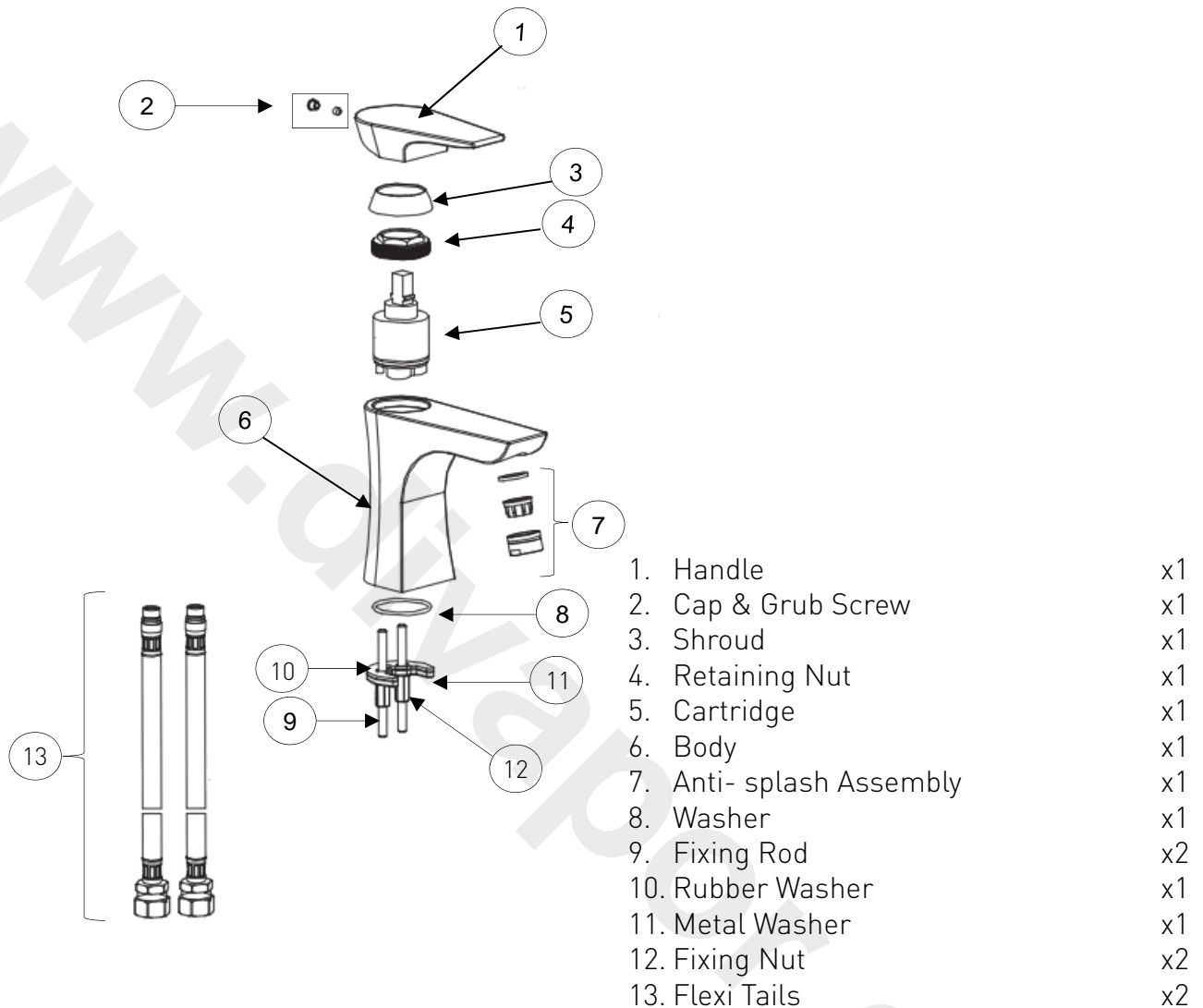

1. Identify all components are present prior to starting installation.
2. Install mixer to the bath, ensuring the washer (8) is fitted between the mixer body (6) and the bath.
3. Screw the fixing rods (9) into the bottom of the mixer body (6).
4. Slide 'C' shaped rubber washer (10) and 'C' shaped metal washer (11) onto the fixing rods (9) up to underside of the bath.
5. To secure the mixer in place tighten the fixing nuts (12) onto the fixing rods (9) until they are fully tightened against the 'C' shaped metal washer (11).
Note: The fixing nuts (12) can be tightened with a suitable spanner.
6. Screw the flexi tails (13) into the bottom of the mixer body (6) and tighten by **hand only (do not overtighten)**
7. Connect the hot and cold water supplies to the flexi tails.
8. Turn on both water supplies, lift the mixer handle (1) upwards and operate in both directions, letting the water flow for a few minutes
9. Check all joints and connections for leaks.

Installation cont.

3 Hole Basin Mixer & Bath Filler

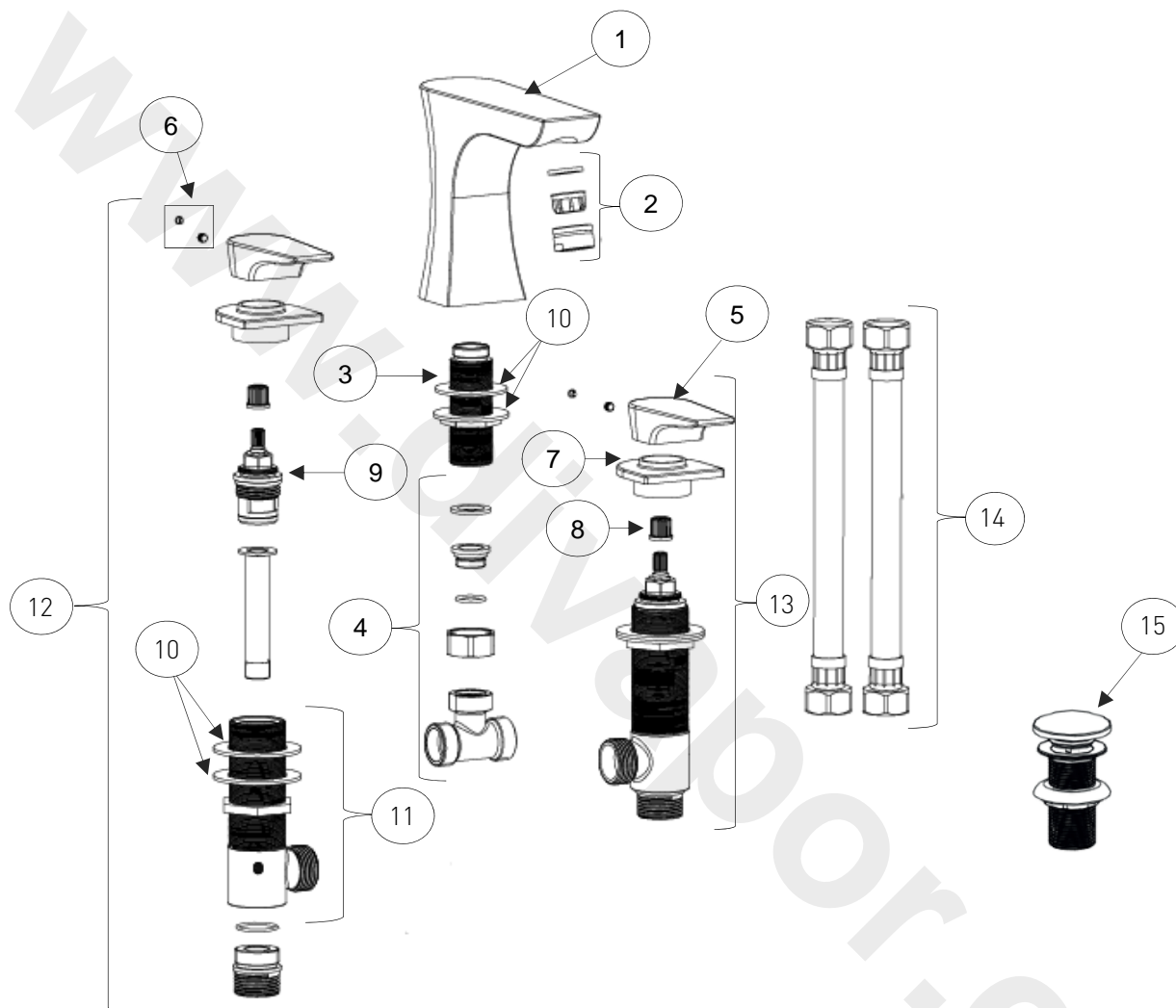

- | | | | |
|--------------------------|----|----------------------------------|----|
| 1. Spout | x1 | 9. Valve | x2 |
| 2. Anti- splash Assembly | x1 | 10. Washer & Backnut | x3 |
| 3. Spout Threaded Tail | x1 | 11. Side Body Threaded Tail | x2 |
| 4. T-Joint Assembly | x1 | 12. Hot Tap Body Assembly | x1 |
| 5. Handle | x2 | 13. Cold Tap Body Assembly | x1 |
| 6. Cap & Grub Screw | x1 | 14. Flexi tails | x2 |
| 7. Plinth | x2 | 15. Complete Clicker Waste | x1 |
| 8. Spline adaptor | x2 | (supplied with Basin Mixer only) | |

Installation cont.

3 Hole Basin Mixer & Bath Filler

1. Identify all components are present prior to starting installation.
2. Unscrew the plinth (6) from threaded tail (11) to remove the handle (4).
3. Fit the side body threaded tails (11) to the underside of the basin and secure in place by screwing the plinth (6) and handle (5) back on to the threaded tails (11), and tighten the backnuts (10).
4. Unscrew the T-Joint assembly (4), washers and backnut (10) from the thread of the spout (1) and fit the spout (1) to the basin tightening the backnut (10).
5. Re-attach the T-joint assembly (4) and connect to the side bodies (11&12-hot on the left, cold on the right when viewed from the front) by using the flexi tails provided.
6. Connect the hot and cold water supplies to the side bodies (hot to the left hand side), fully open both valves, letting them run for a few minutes to flush the system.
7. Fit the clicker waste (15) (basin mixer only) ensuring a rubber washer is fitted between the basin and the waste. Use a pure silicon sealant where necessary. Place the other rubber washer under the basin and secure in place by tightening the backnut. In order to fill the basin, the button in the middle of the waste needs to be pressed down. To release the water, press the button again.
8. Check all joints and connections for leaks.

Installation Cont.

5 Hole Bath Shower Mixer

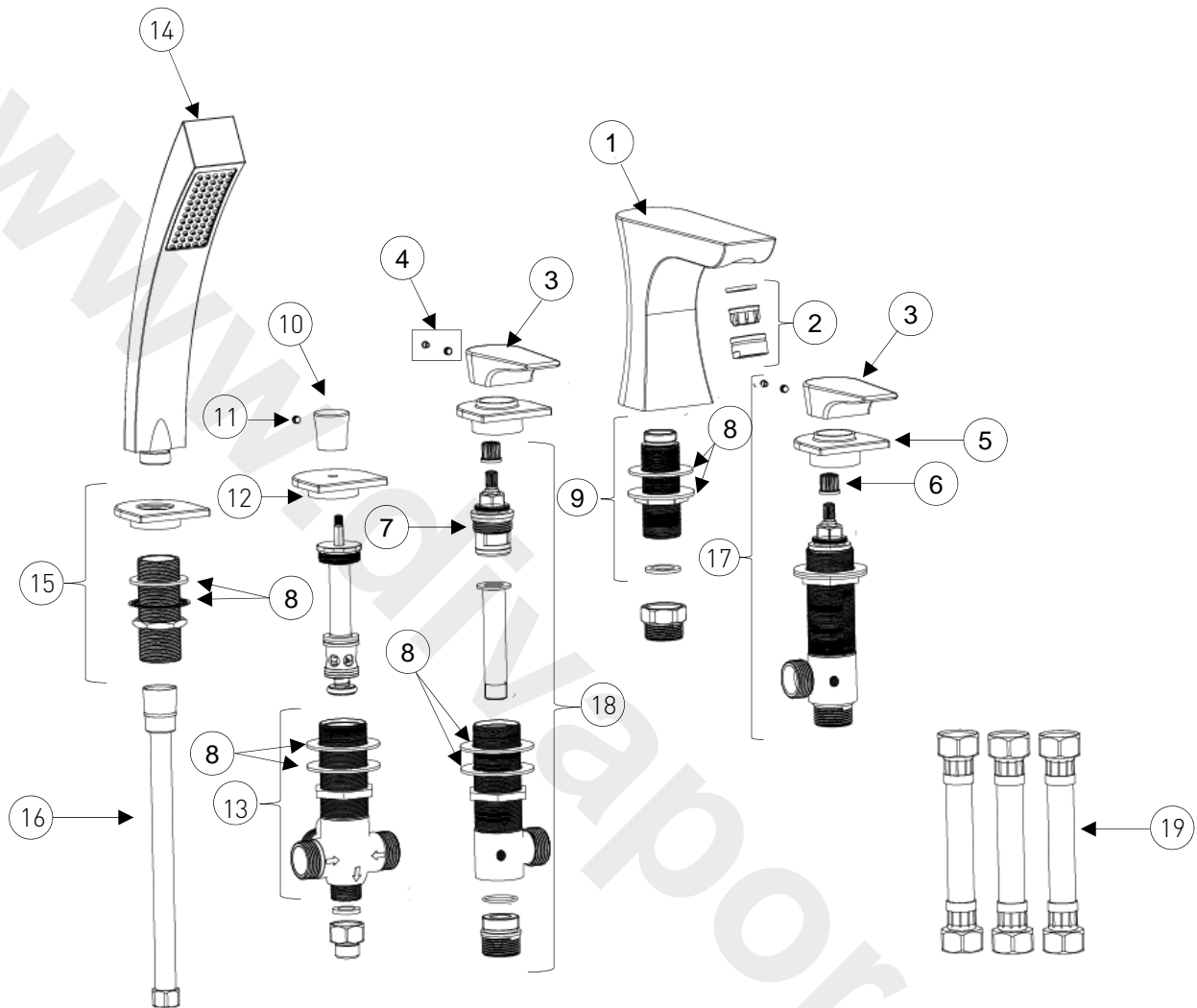

- | | | | |
|--------------------------|----|-----------------------------|----|
| 1. Spout | x1 | 11. Diverter Grub Screw | x1 |
| 2. Anti- Splash Assembly | x1 | 12. Diverter Plinth | x1 |
| 3. Handle | x2 | 13. T- joint assembly | x1 |
| 4. Cap & Grub Screw | x2 | 14. Handset | x1 |
| 5. Plinth | x2 | 15. Handset Connection | x1 |
| 6. Spline adaptor | x2 | 16. Hose | x1 |
| 7. Valve | x2 | 17. Cold Side Body Assembly | x1 |
| 8. Backnut & Washer | x4 | 18. Hot Side Body Assembly | x1 |
| 9. Spout Threaded Tail | x1 | 19. Flexi Tails | x3 |
| 10. Diverter knob | x1 | | |

Installation Cont.

5 Hole Bath Shower Mixer

1. Identify all components are present prior to starting installation.
2. Remove the handles (3) from the side bodies (17 & 18) by removing the cap (4) and loosening the grub screw (4) at the rear of the handle (3)
3. Unscrew the plinths from the side bodies (5).
4. Fit the side bodies (17 & 18) to the bath from underneath and screw the plinths (5) onto the side bodies (17 & 18).
Secure the side bodies by tightening the backnuts (8)
5. Fit the spout (1) to the bath secure by tightening the backnut (8).
6. Unscrew the diverter knob (10) and plinth (12) from the diverter and fit the diverter body to the bath. Re-fit the plinth (12) and diverter knob (10) and tighten backnut (8) to secure into position.
7. Fit the handset connection (15) to the bath and secure in place by tightening the backnut (8)
8. Connect the flexi hoses (19) from the side bodies (17 & 18) to the T-joint (13). The other flexi hose connects the T-joint (13) to the spout threaded tail (9)
9. Screw the shower hose (16) onto the handset (14) and thread the hose through the handset connection (15). Screw the hose (16) onto the back outlet of the T-joint (13).
10. Connect the water supply pipes to the side body threaded tails (17 & 18)
11. Turn on both, hot and cold taps letting the water flow for several minutes to flush the system and check for any leaks.
12. To switch from bath fill to shower mode pull the diverter knob (10) up. To revert back to bath fill mode, while in use, push the diverter back down. The bath shower mixer will automatically revert back to bath fill if turned off while in shower mode.

Maintenance

General Cleaning

Your fitting has a high quality finish and should be treated with care to preserve the visible surfaces. All finishes will wear if not cleaned correctly. The only safe way to clean your product is to wipe with a soft damp cloth. Stains can be removed using washing up liquid. All bathroom cleaning products (powders and liquids) will damage the surface of your fitting, even the non-scratch cleaners.

Note: Never use abrasive detergents or disinfectants or those containing alcohol, hydrochloric acid or phosphoric acid.



Bristan recommend E-cloth for cleaning all of our bathroom & kitchen products. Using just water, E-cloth gives a smear free, deep clean by breaking up and holding dirt, which normal cloths leave behind. Order through your Bristan stockist (order code: E CLOTH).

We advise that your fitting is regularly serviced in hard water areas to maintain optimum performance.

Cleaning the Showerhead:

HOU 5HBSM C

Your Bristan showerhead has rub-clean nozzles for easy cleaning. Simply rub your fingers across the rubber spray jets regularly and before you turn the shower on to remove any scale or debris.

The hardness of the water in your area will determine how often you should clean your showerhead. Build up of scale in particularly hard water areas combined with constant use means you may need to clean your showerhead once a week. To ensure continued performance the showerhead needs to be regularly descaled.

Tip: If the showerhead is heavily scaled or has not be maintained for a long period of time a solution of hot water and white vinegar may be needed to clear the scale.

Mix a 50/50 solution and rub the nozzles thoroughly with the solution making sure the solution gets into all of the nozzles.

Wash off the solution with clean water.

Maintenance cont.

Cleaning the Valves:

If your fitting begins to leak the following should be carried out;

Isolate both hot and cold water supplies to the tap by either:

- Turning the water supply off at the mains stopcock or
- Turning off the isolation valves to the tap.

1. Remove the cap at the rear of the handle to reveal the concealed grub screw.
2. Unscrew the grub screw and pull the handle upwards.
3. Unscrew the valve from inside of the side body using a suitable spanner.
4. Lift out the valve and clean thoroughly. Be sure to check and clean out the seating within the tap body/assembly.
5. If necessary replace the valve.

Please visit www.bristan.com/sparesfinder in order to find spare parts for this product.

6. Place the valve back into the tap side body and tighten the valve fully using a suitable spanner.
7. Replace handle assembly push the handle onto the valve. Tighten the grub screw and push fit the cap.

Note: It may be necessary to tighten the backnut.

8. Turn on water supply and check for leaks.
9. Contact our helpline if problem persists.

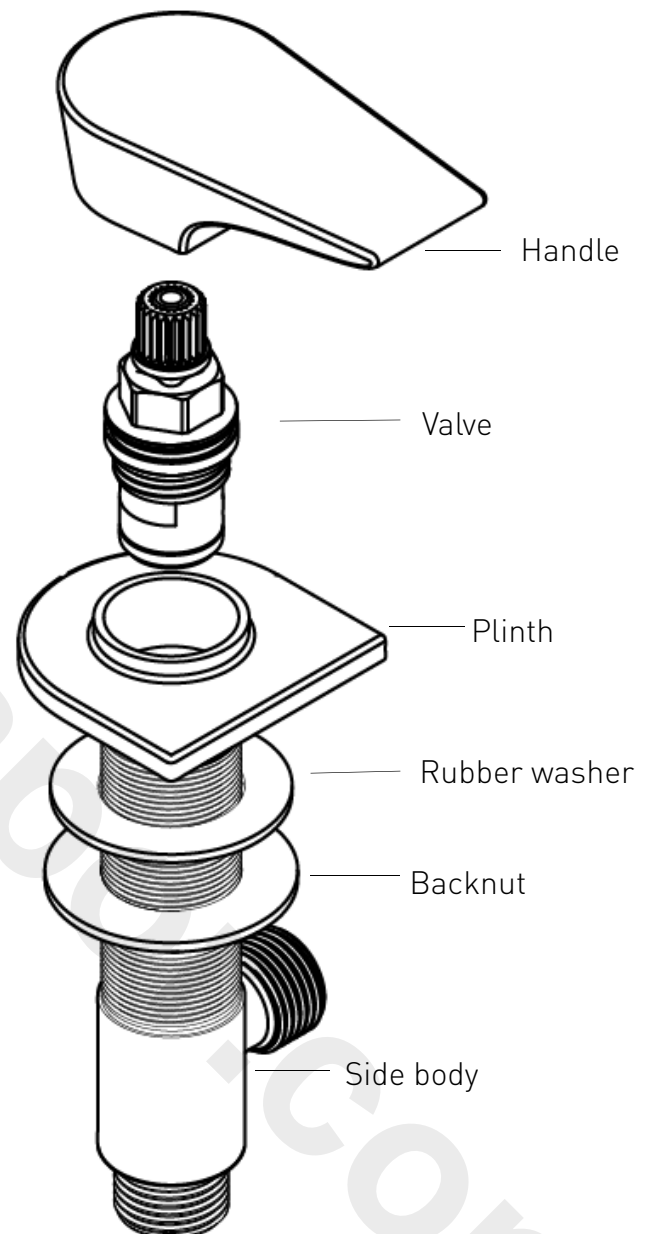

Maintenance cont.

Cleaning the Cartridge:

If your fitting begins to leak the following should be carried out;

Isolate both hot and cold water supplies to the tap by either:

- Turning the water supply off at the mains stopcock or
- Turning off the isolation valves to the tap.

1. Remove the cap at the rear of the handle to reveal the concealed grub screw.
2. Unscrew the grub screw and pull the handle upwards.
3. Unscrew the shroud and cartridge retaining nut and pull the cartridge out from the body.
4. Clean the cartridge thoroughly under cold water to remove any build up of limescale or debris.

Please visit www.bristan.com/sparesfinder in order to find spare parts for this product.

4. Replace the cartridge into the body and tighten the retaining nut to secure in place.
5. Screw the shroud onto the retaining nut and push the handle onto the cartridge. Tighten the grub screw and push fit the cap.

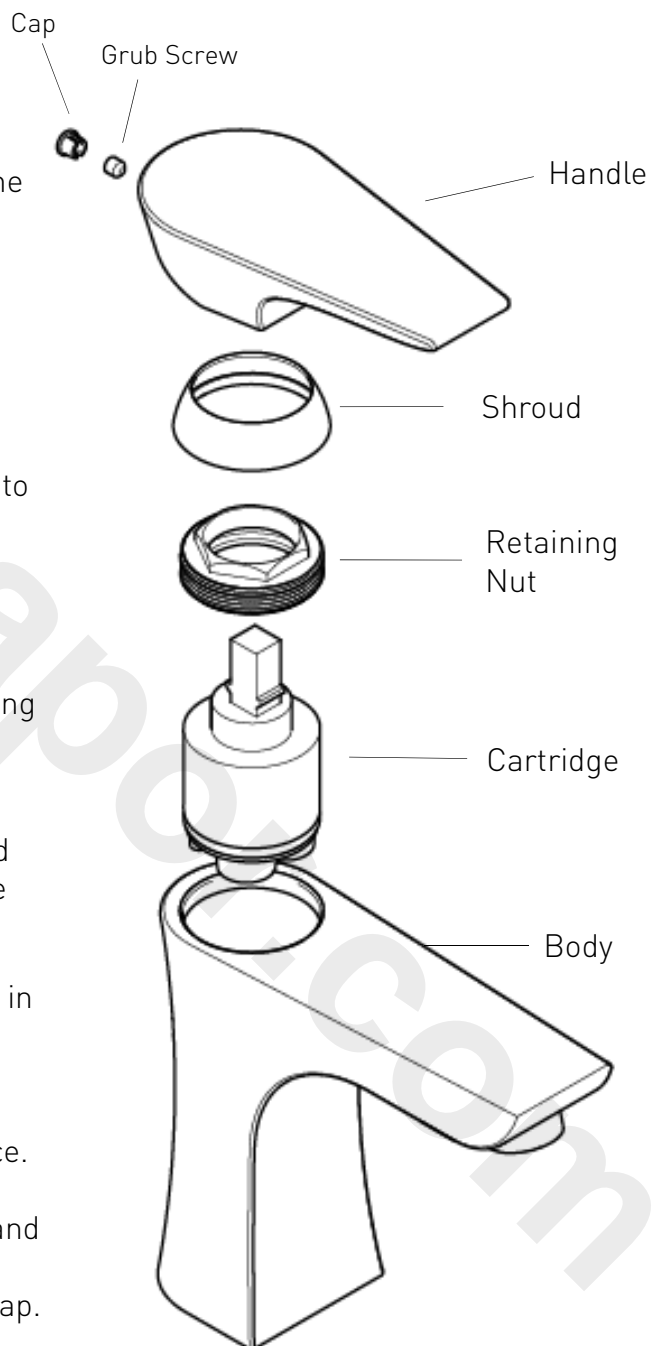

Troubleshooting

Symptom	Cause	Remedy
No flow or poor flow rate.	Partially closed stop or service valve in water supply pipework to the tap.	Open stop or service valve.
	Head of water is below the minimum distance required.	Refer to the Specification section for minimum pressures required.
	Possible airlock / blockage in supply pipework	Remove water supplies from the fitting and flush the system to remove any airlocks / debris.
	Cartridge / Valve not opening fully.	Service fitting. Refer to maintenance section on pages 11-12.
Water dripping for a few seconds after the tap has been turned off.	This is caused by 'capillary action' and residual water in the spout being siphoned out.	This should only last for a couple of seconds.
Constant dripping / leaking when the tap is not in use.	Cartridge / Valve not fully shutting off.	Service fitting and replace cartridge. Refer to maintenance section on page 11-12.
Fitting does not turn on.	Water supplies not turned on.	Check that the water supplies to the fitting are turned on.
	Closed stop or service valve.	Open stop or service valve.
Water does not come out of the showerhead when using the bath shower mixer.	Diverter mechanism not fully open.	Ensure diverter is pulled fully up.
	Insufficient water pressure / header height.	Refer to the specification section for minimum pressures required.

Bristan Guarantee

At Bristan, we want to make things as easy as possible for our customers. That's why we design products that are easy to fit and use, and that are quality tested to make sure they won't let you down. It's also why we offer solid guarantees on all products, effective from the date of purchase, to give you peace of mind.

All Bristan taps are covered by a **5 year guarantee**. This also includes **2 years labour cover** which means that, in the unlikely event that there is a problem in the first 2 years after purchase, we'll send one of our expert engineers to fix it.

*Labour is provided by an approved Bristan Care engineer or appointed representative. The guarantee only applies to products with a manufacturing fault. There will be a call out charge for any incidents where no fault has been found with the product, or if the issue is due to poor installation or maintenance.

Guarantee Terms and Conditions

This guarantee is in addition to your statutory and other legal rights and is subject to the following conditions:

- The product was purchased within the United Kingdom or Republic of Ireland.
- The guarantee applies solely to the original purchaser with proof of purchase.
- The installation must allow ready access to all products for the purpose of inspection, maintenance or replacement.

- Repair under this guarantee does not extend the original expiry date. The guarantee on any replacement parts or product ends at the original expiry date.

- Any part found to be defective during the guarantee period will be replaced without charge, providing that the product has been installed in accordance with the instructions given in this guide and used as the manufacturer intended.

- The guarantee does not cover:

- Damage or defects caused by:

- general wear and tear (including special non-chrome finishes; components such as filters, seals, 'O' rings and washers)
- incorrect installation
- repair using non-Bristan parts
- accidental or wilful misuse
- corrosion and the use of inappropriate cleaning products.
- system debris including the build up of limescale (which can be controlled through regular servicing and maintenance).

- Compensation for loss of use of the product or consequential loss of any kind.

In the interests of continuous product improvement, Bristan reserves the right to alter product specifications without notice.

The Bristan Product Guarantee does not affect your statutory rights as a consumer.

•Need help?

If this product does not function correctly when first used, contact **Bristan Care Customer Service on 0844 701 6273** where our expert team of advisors will be able to offer you help and advice.

•Problems during the guarantee period

In the unlikely event that you encounter any problems with the product during the guarantee period, contact **Bristan Care Customer Service on 0844 701 6273** with your proof of purchase and we will work to resolve the problem quickly.

Bristan Care Customer Support

Bristan customers also benefit from the support of Bristan Care, our comprehensive customer support package which offers:

Technical support hotline

(Tel: **0844 701 6273**) with access to fully trained advisors who can offer installation advice, talk you through quick maintenance checks, or recommend the best course of action to fix any problems with a product

Expert advice

Find easy to follow 'how to' video guides and technical FAQs online at www.bristan.com. Our guides take you step-by-step through many product installations and you can find plenty of easy guides to quick product fixes and servicing.

Spare parts

We hold thousands of spares and we keep them for discontinued products for over seven years. Spares can easily be ordered online at www.bristan.com and are dispatched the same day.

Expert plumbing engineers

If we can't solve the problem over the 'phone or with a spare part, then we'll send out one of our Bristan Care engineers to take a look. Bristan Care engineers provide free support for products that are within guarantee, but are also available to service products that are out of guarantee for a small charge. For details, please call customer services on **0844 701 6273**.

BRISTAN

This booklet covers product codes

HOU 1HBF C

HOU 3HBAS C

HOU 3HBF C

HOU 5HBSM C

Helpline

0844 701 6273

Bristan Group Limited

Birch Coppice Business Park, Dordon, Tamworth, Staffordshire B78 1SG

A Masco Company

Website: www.bristan.com

Telephone: 0844 7016 274 Facsimile: 0844 701 6275

Email: enquire@bristan.com